

IMPORTANT - READ OPERATOR'S MANUAL BEFORE OPERATING OR MAKING ADJUSTMENTS

## Body Removal

1. The 304 has a (2) piece fabricated steel body. The upper body can be folded forward to expose the transaxle. In some cases, it may be necessary to remove the upper body to service the transaxle.
2. To remove upper body, fold forward and remove bolt (P/N 3006) from cable (P/N 3780). Shut upper body and remove the two cotter pins (P/N 3058) from the front of upper body support. Carefully lift upper body from frame.
3. Reverse above procedure to reinstall.

## Seat Adjustment

1. Raise upper body.
2. Loosen four seat bolts (P/N 3093) and slide seat forward or backward to desired position.
3. Retighten bolts.

## Mower Blade Operation

To engage the mower blades, turn lever on floor, slowly, to the "ON" position. To disengage mower blades, turn lever, slowly, to the "OFF" position.

## Removing Mower Deck

1. Loosen the belt keeper (P/N 7026 & 7027), located under the engine, by loosening two rear engine mounting bolts, allowing the deck drive belt to come free of the rear pulley.
2. Disconnect the wiring loom at the deck safety switch (P/N 4242).
3. Remove the two clevis pins (P/N 3072) from the two rear L-rods (P/N 1355) and slide from slots.
4. Remove clevis pin (P/N 3072) from L-rod attached to lift handle and slide from slot.
5. Remove clevis pin (P/N 3072) from front deck hanger shaft (P/N 1332), located at front of mower deck on slide plates welded at battery box, and remove.
6. Lift front of mower chassis and roll free of the deck.
7. To install, reverse the above procedure.

## Adjustment of Mower Deck Drive Belt

1. The mower deck drive belt is tensioned by a spring loaded engagement idler quadrant.
2. This system is designed to maintain the proper belt tension at all times.
3. Belt tension can be adjusted by moving the engaging rod (P/N 7013) into the outside hole of engagement handle (P/N 1414).
4. After belt tension is adjusted, check to assure that the mower blade will not turn freely when the engaging rod is in the "OFF" position.
5. If the mower blade turns freely, adjust the blade by loosening nut (P/N 3205) at end of the brake linkage (P/N 7015).
6. After adjustment is achieved, perform the safety checks listed below.

## "IMPORTANT" - Perform Safety Checks After Making Any Repairs Or Adjustments

1. After reassembly, while seated on mower, attempt to start engine with mower deck engaged. Engine should not start. If engine does start, return the mower to an Authorized Dixon Dealer for adjustment or repair.
2. Disengage mower deck and start engine. With the operator in the normal seated position, engage mower deck and remove weight from seat. The engine should stop. If the engine does not stop when operator rises from seat, return the mower to an Authorized Dixon Dealer for adjustment or repair.
3. Engage, then disengage, mower blade in each cutting height. Insure that blade disengages and comes to a stop within (5) seconds in each height position. If blade does not disengage properly, contact your Authorized Dixon Dealer.

## Parking Brake Adjustment

1. Raise upper body to the open position.
2. Tighten nut on brake rod (P/N 2533), located in front of the transaxle on each side, just enough to prevent brake from slipping when engaged.

CAUTION: Over tightening may cause premature wear on the brake band (P/N 5085).

## Removing The Mower Blade

Secure blade (P/N 2483) from turning. Remove blade bolt from center of blade (P/N3268), lock washer (P/N 3065) and blade washer (P/N 6113), then remove blade (P/N 2483).

To reinstall, reverse above procedure.

Warning: Sharp edges on blade can cause Injury! Caution should be exercised when service is required on blade.









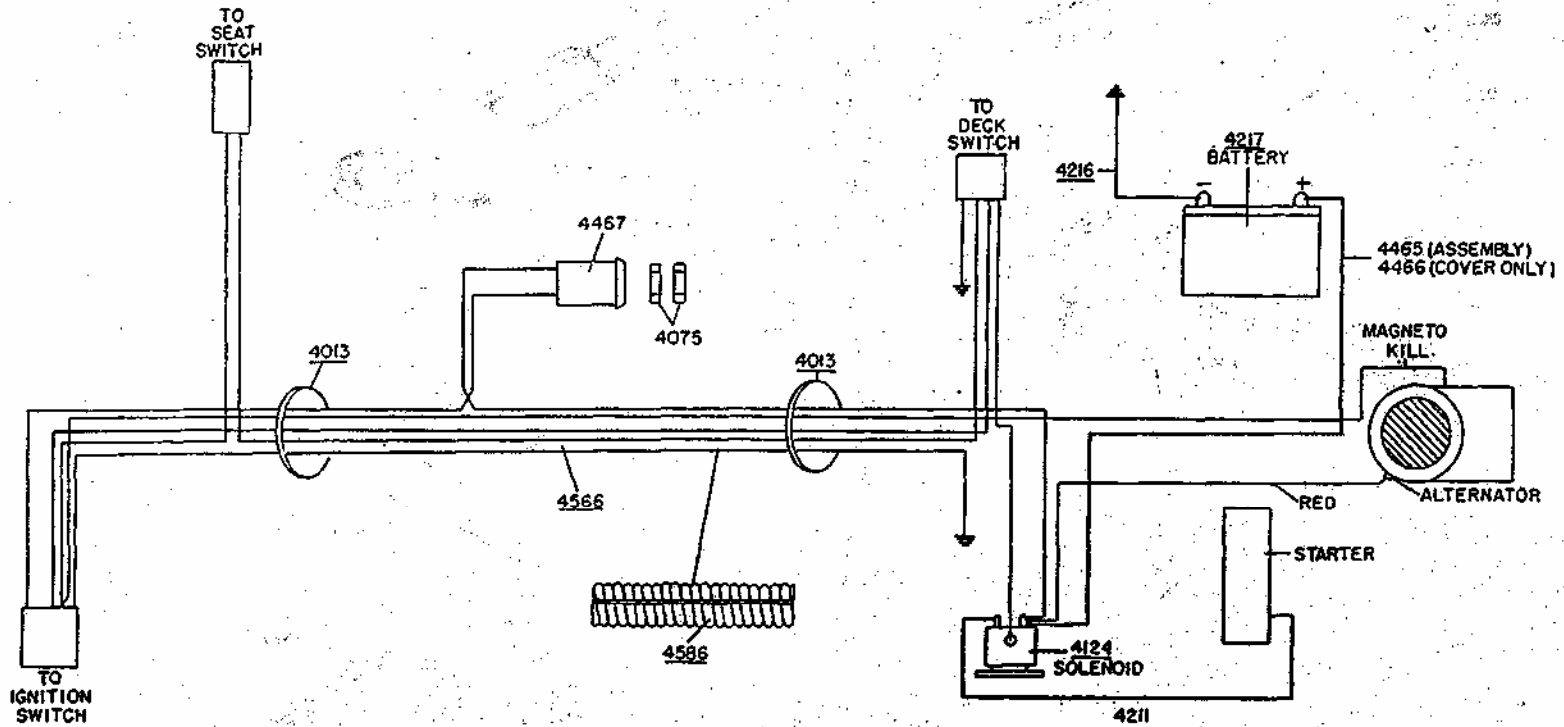

WIRING (MODEL 7TD 30A1)