

DIXON® ZTR Mowers DIXON® ZTR Mowers DIXON® ZTR Mowers DIXON® ZTR Mowers



Operator's Manual

DIXON® ZTR Mowers DIXON® ZTR Mowers DIXON® ZTR Mowers DIXON® ZTR Mowers

DIXON® ZTR Mowers DIXON® ZTR Mowers DIXON® ZTR Mowers DIXON® ZTR Mowers

DIXON® ZTR Mowers DIXON® ZTR Mowers DIXON® ZTR Mowers DIXON® ZTR Mowers

DIXON® ZTR Mowers DIXON® ZTR Mowers DIXON® ZTR Mowers DIXON® ZTR Mowers

4000 SERIES ZTR® MOWERS

DIXON® ZTR Mowers DIXON® ZTR Mowers DIXON® ZTR Mowers DIXON® ZTR Mowers

DIXON® ZTR Mowers DIXON® ZTR Mowers DIXON® ZTR Mowers DIXON® ZTR Mowers

2001

IMPORTANT: READ CAREFULLY

The Dixon® ZTR® Mower is both easy and fun to operate. However,
any power mower must be operated properly to be safe.
It is not a toy or a recreational vehicle.

Before you start to use the mower: read the operator's manual carefully,
and become completely familiar with the controls.

The information in this operator's manual applies to all
Dixon® ZTR® 4000 Series Model Mowers.

Your Dixon dealer will gladly answer any questions.

See your dealer for warranty service, parts and repairs.



DIXON INDUSTRIES, INC.
A BLOUNT International Inc. Co.
PO BOX 1569
COFFEYVILLE KS 67337 0945
316 251 2000

BLOUNT

INDEX

SAFETY	Pages	4 - 9
WARRANTY POLICY	Page	10
SPECIFICATIONS	Page	11
SEAT ADJUSTMENT	Page	12
CONTROLS	Pages	13 - 15
OPERATION INSTRUCTIONS	Pages	16 - 21
CARE AND MAINTENANCE	Pages	22 - 30
STANDARD PARTS LIST	Page	31
TROUBLESHOOTING	Pages	32 - 34

4000 Series
Part No. 13087-0400

SAFETY

***RIDING LAWNMOWERS, IF IMPROPERLY OPERATED,
CAN CAUSE SERIOUS INJURY OR DEATH***

The most common causes of injury to the operator or bystander...

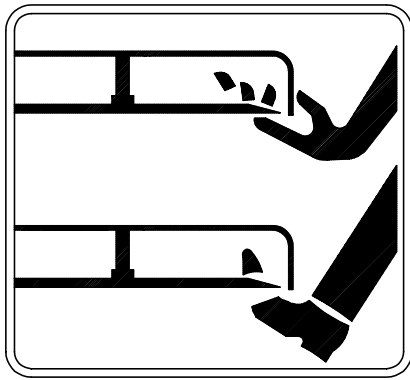

BLADE CONTACT



TIP-OVER

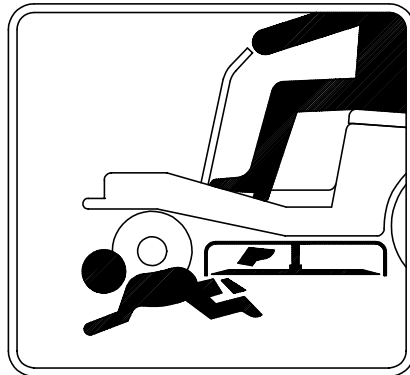

RUN-OVER

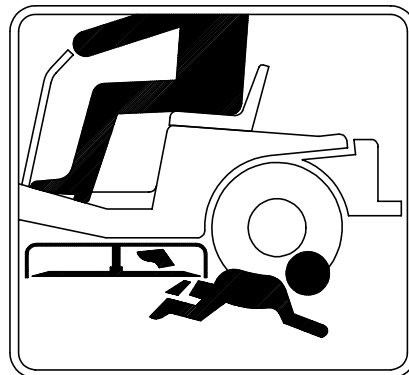

BACK-OVER

...read and understand this manual to prevent injuries.

SAFETY

SAFETY SYMBOLS



Safety Alert Symbol

When you see this symbol,
BE ALERT to the potential for injury.

*Follow recommended safety precautions and safe
operating practices.*



Danger

indicates an imminently hazardous situation
which, if not avoided, will result in death or
serious injury.



Warning

indicates a potentially hazardous situation
which, if not avoided, could result in death or
serious injury.



Caution

indicates a potentially hazardous situation
which, if not avoided, may result in minor or
moderate injury. It may also be used to alert
against unsafe practices.

SAFETY

This cutting mower is capable of amputating hands & feet, and throwing objects. Failure to observe the following safety instructions could result in serious injury or death.

GENERAL OPERATION:

- Read, understand, and follow all instructions in the manual and on the mower before starting.
- Only allow responsible adults, who are familiar with the instructions, to operate the mower.
- Clear the area of objects such as rocks, toys, wire, etc., which could be picked up and thrown by the blade.
- Be sure the area is clear of other people before mowing. Stop mower if anyone enters the area.
- Never carry passengers.
- Do not mow in reverse unless absolutely necessary. Always look down and behind before and while backing.
- Be aware of the mower discharge direction and do not point it at anyone. Do not operate the mower without either the entire grass catcher or the deflector in place.
- Slow down before turning.
- Never leave a running mower unattended. Always turn off blades, set parking brake, stop engine, and remove key before dismounting.
- Turn off blades when not mowing.
- Stop engine before removing grass catcher or unclogging chute.
- Mow only in daylight or good artificial light.
- Do not operate the mower while under the influence of alcohol or drugs.
- Watch for traffic when operating near or crossing roadways.
- Use extra care when loading or unloading the mower into a trailer or truck. Do not ride the mower when loading & unloading.
- Always wear safety goggles or safety glasses with side shields when operating mower.
- Data indicates that operators, age 60 years and above, are involved in a large percentage of riding mower-related injuries. These operators should evaluate their ability to operate the riding mower safely enough to protect themselves and others from serious injury.
- Follow the manufacturer's recommendation for wheel weights or counterweights.
- Maintain or replace safety & instruction labels, as necessary.

 **WARNING:** The engine exhaust from this product contains chemicals known to the State of California to cause cancer, birth defects or other reproductive harm.

 **SAFETY*****SLOPE OPERATION:***

Slopes are a major factor related to loss-of-control and tip-over accidents, which can result in severe injury or death.

All slopes require extra caution.

If you cannot back up the slope or if you feel uneasy on it, do not mow it!

DO

Mow across the slope with your Dixon ZTR - never up or down.

Remove obstacles such as rocks, tree limbs, etc.

Watch for holes, ruts or bumps. Uneven terrain could overturn the mower. Tall grass can hide obstacles.

Use slow speed. Tires may lose traction on slopes even though the brakes are functioning properly.

Use extra care with grass catchers or other attachments. These can change the stability of the mower.

Keep all movement on the slopes slow and gradual. Do not make sudden changes in speed or direction.

Avoid starting or stopping on a slope. If tires lose traction, disengage the blades and proceed slowly down the slope.

If front wheels lift off the ground, pull the levers back to stabilize the mower.

DO NOT

Do not turn on slopes unless necessary, and then, turn slowly and gradually downhill, if possible.

Do not mow near drop-offs, ditches, or embankments. The mower could suddenly turn over if a wheel is over the edge of a cliff or ditch, or if an edge caves in.

Do not mow on wet grass. Reduced traction could cause sliding.

Do not try to stabilize the mower by putting your foot on the ground.

Do not use grass catcher on steep slopes.

 **SAFETY*****CHILDREN:***

Tragic accidents can occur if the operator is not alert to the presence of children.

Children are attracted to lawn mowers and the mowing activity.

NEVER assume children will stay where they were last seen.

Be alert to avoid accidents.

- **Keep children out of the mowing area and under the watchful care of another responsible adult.**
- **Be alert and turn mower off if a child enters the area.**
- **Before and during backing, look behind and DOWN for small children.**
- **Never carry children. They may fall off and be seriously injured or interfere with safe mower operation.**
- **Never allow children to operate the mower.**
- **Use extra care when approaching blind corners, shrubs, trees, or other objects that may obscure vision.**



SAFETY

SERVICE:

- Use extra care in handling gasoline and other fuels. They are flammable and vapors are explosive.

Use only an approved container.

Never remove gas cap or add fuel with the engine running. Allow engine to cool before refueling. Do not smoke.

Never refuel the mower indoors.

Never store the mower or fuel container inside a building where there is an open flame,

If fuel is spilled on clothing, change clothing immediately.

To prevent fire and explosion caused by static electricity:

Never fill containers inside a vehicle or on a truck or trailer bed with a plastic liner. Always place containers on the ground away from your vehicle before filling.

When practical, remove gas-powered equipment from the truck or trailer and refuel it on the ground. If this is not possible, then refuel such equipment on a trailer with a portable container, rather than from a gasoline dispenser nozzle.

If a gasoline dispenser nozzle must be used, keep the nozzle in contact with the rim of the fuel tank or container opening at all times until fueling is complete. Do not use a nozzle lock-open device.

- Never run a mower inside a closed area. The exhaust fumes are toxic.
- Keep nuts and bolts tight, especially blade attachment bolts, and keep equipment in good condition.
- Never tamper with safety devices. Check their proper operation regularly.
- Keep mower free of grass, leaves, or other debris buildup. Clean up oil or fuel spillage. Allow mower to cool before storing.
- Stop and inspect the equipment if you strike an object. Repair, if necessary, before restarting.
- Never make adjustments or repairs with the engine running.
- Grass catcher components are subject to wear, damage, and deterioration, which could expose moving parts or allow objects to be thrown. Frequently check components and replace with original equipment parts, when necessary.
- Mower blades are sharp and can cut. Wrap the blade(s) or wear gloves, and use extra caution when servicing them.
- Batteries contain sulfuric acid. To prevent burns avoid contact with skin, eyes and clothing. To prevent a fire or explosion keep sparks and open flames away from battery.
- Before disconnecting the negative (-) ground cable, make sure all switches are OFF.
- Check to assure that the drive chains are properly adjusted. A loose chain may come off causing loss of control.



DIXON LIMITED WARRANTY POLICY - 3000 & 4000 SERIES

WARRANTY: Home Owner Application: This Dixon Warranty term is for a period of two (2) years from date of purchase. **Commercial Application:** Dixon mowers used for commercial application are warranted for 30 days from the date of purchase. Commercial use is specified as use other than, or in addition to, mowing at owner's primary place of residence.

DIXON ZTR MOWERS ARE WARRANTED AGAINST DEFECTS IN MATERIALS AND WORKMANSHIP AND PROVIDES FOR REPLACEMENT OR REPAIR OF PARTS INCLUDING LABOR COSTS. THIS WARRANTY IS SUBJECT TO THE FOLLOWING CONDITIONS AND LIMITATIONS:

1. Warranty applies only to original retail purchaser of new and unused mowers and accessories.
2. All Dixon warranty must be accomplished by authorized Dixon dealers and in accordance with Dixon warranty policy and allowances. All warranty claims must be approved by Dixon Industries, Inc.
3. Battery warranty: Limited to 90 days from date of purchase.
4. Accessories Warranty (Grass Catchers, Snow Blades, Covers, etc.): Limited to 90 days from date of purchase.
5. Warranty does not apply to damage in transit or incidents of misuse, negligence, accidents, or alteration. The use of parts or components other than those supplied by Dixon Industries, Inc. **VOIDS ALL WARRANTY.**
6. The following items are not covered by this warranty policy:
 - (a) Pick up and delivery charges for transportation of mower to and from an Authorized Dixon dealer's place of business.
 - (b) Transaxle adjustments.
 - (c) Belts/chains/sprockets/cutting blades.
 - (d) Engines -- All engines used on Dixon ZTR mowers are warranted by each individual engine manufacturer.
 - (e) Any costs or expense of providing substitute equipment while repair work is being performed on a warranted mower.
7. There is no other express warranty. Implied warranties, including those of merchantability and fitness for a particular purpose, are limited to the same duration of the express warranty, and to the extent permitted by law any and all implied warranties are excluded. Liabilities for consequential damages under any and all warranties are excluded.

Blue/Customer Yellow/Dealer White/Dixon Ind.

WARRANTY VALIDATION: At the time of sale, selling dealer must review each portion of this warranty document, complete the information section below, secure customer's signature and send copy to Dixon Industries, Inc.

DATE OF PURCHASE _____ Model _____ S/N _____

Owner's Name _____

Dealership _____

Address _____

Address _____

Owner's Signature _____

Dealer's Signature _____

SPECIFICATIONS

Models ZTR 4423

CHASSIS: Twin 12 gauge side frames and 7 gauge transmission and engine base plate.

BODY: All body parts are made of high density polyethylene. Dent and corrosion resistant. Front body contains access panel for battery service.

MOWER DECK: 13 GA stamped steel construction.
(3) blades combine for a 42" cut width.
Cut height approximately 1" to 4" via 7 position lift handle.

BLADE DRIVE: Electric clutch.

TRANSMISSION: Each rear wheel is independently driven by chain and sprockets through a mechanical friction drive.

ENGINE: 15.5HP Vanguard Briggs & Stratton, 4-Cycle, Single Cylinder, Overhead Valve, Air-Cooled, Gasoline, Vertical Shaft With Cast Iron Cylinder Sleeve, Pressure Lubricated with oil filter.

STARTING SYSTEM: Electric by key switch operation with safety interlock blade drive.

TIRES: Front 11 X 4.00 X 5 ribbed tread.
Rear 18 X 9.50 X 8 Turf Trac RS

**RECOMMENDED
TIRE PRESSURE:** Front 16-21 lbs.
Rear 8-14 lbs.

CAPACITIES: Fuel 2.7 gallons total.
Engine 1.50 quarts oil.

DIMENSIONS: Width 47" outside rear wheel measurement.
Height 42" to top edge of seat.
Length 72" hitch tab to front bumper.
Weight 520 lbs.

NOTE: Additional information provided in service instructions under the individual component.

SPECIFICATIONS SUBJECT TO CHANGE WITHOUT NOTICE

SEAT ADJUSTMENT INSTRUCTIONS

1. Place parking brake in ON position. (Pull brake lever up)
2. Raise and push seat assembly forward.
3. Loosen five nuts, P/N 3205, and slide seat forward or backward to desired position.
Retighten nuts, P/N 3205.

DO NOT operate mower without seat adjustments properly tightened.

4. Raise and push seat assembly and upper body rearward to closed position.

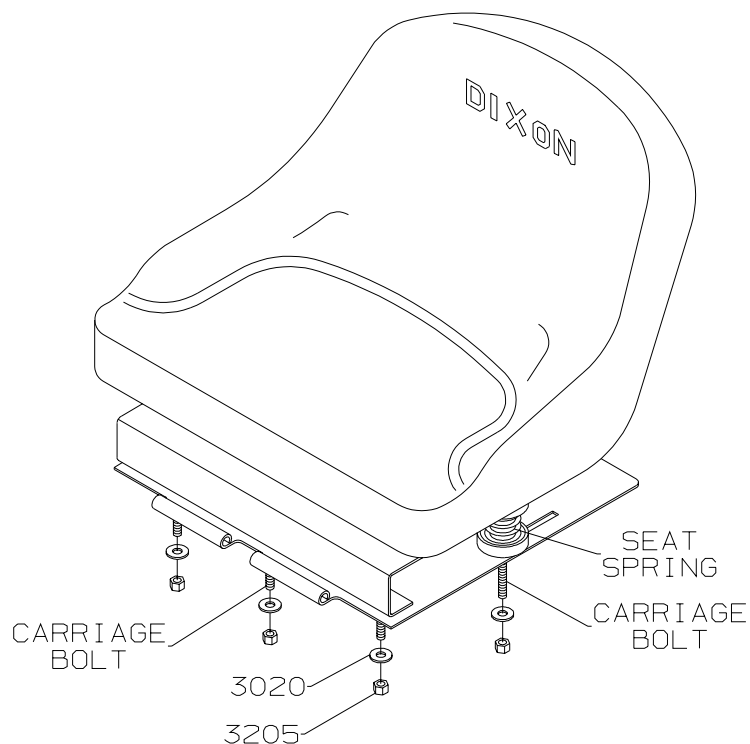

CONTROLS

The Dixon ZTR has a unique transaxle that requires only two drive levers to control braking, turning, speed, and direction.

On initial operation, set throttle speed on slow. Operate with mower blade "OFF".

To avoid "over-controlling" the mower, use a light touch on the drive levers.

Slight movements using fingertip control is all that is necessary.

PARKING BRAKE:

The parking brake is designed to hold the mower from moving and is not intended for use in stopping the mower while it is in motion.

 **CAUTION** Engage parking brake before restarting engine.

TO SET PARKING BRAKE:

The hand operated parking brake is located on the right fender.

To engage brake, pull lever up(to the rear).

To release brake, move lever forward (down).

NOTE: Always set parking brake before dismounting.



TRANSMISSION DRIVE SYSTEM:

Allows the mower to turn on its own axis
"Zero Turning Radius"
Each lever controls one side of the mower.

NOTE: The pressure required to operate the mower is very light.

CONTROLS

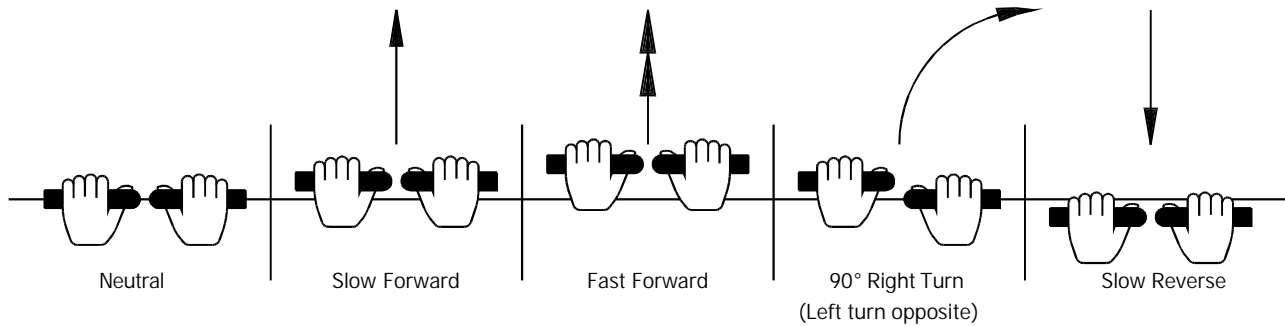

TO GO FORWARD:

From neutral position, gently push both drive levers forward.

To increase speed, move levers farther forward.

TO GO BACKWARD:

From neutral position, gently pull both drive levers toward you.

TURNING:

Turning is controlled by moving one drive lever slightly forward or rearward of the other.

To turn left, move left lever rearward of the right lever.

To turn "square corners" move lever of desired direction to neutral.

To turn on mower's own axis (zero turning radius) stop and move one lever to reverse position and the other to forward position.

BRAKING:

To brake mower, move both levers in direction opposite of travel, release levers to neutral, set parking brake.

THROTTLE CONTROL LEVER:

Located on control panel to operators right.

Throttle control for engine speed.

Choke for engine starting.

Throttle Control should be set to the **MAXIMUM** or wide open setting to insure adequate cooling of the engine and to maintain mower deck blade speed while mowing.

CONTROLS

BLADE DRIVE:

Located on control panel, on operator's right.

To engage the mower blades, pull up on the switch.

To disengage blades, push down.

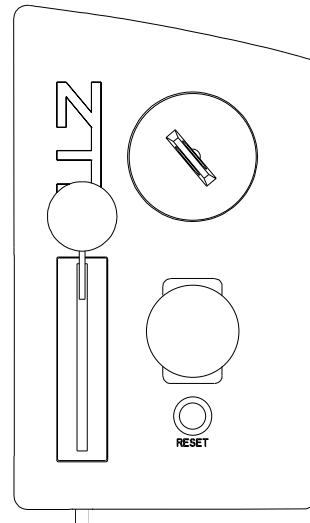

CIRCUIT BREAKER:

Protection of the electrical system is by (1) 15 amp circuit breaker.

If circuit breaker trips, push button to reset.

If this condition repeats, consult dealer for inspection and repair.

MOWER DECK CUT HEIGHT LIFT LEVER:

Located to the left of operator.

Controls the cutting height.

Seven positions of adjustment.

Move lever in and forward to lower.

Move lever in and back to raise.

NOTE: Always use high for transport.

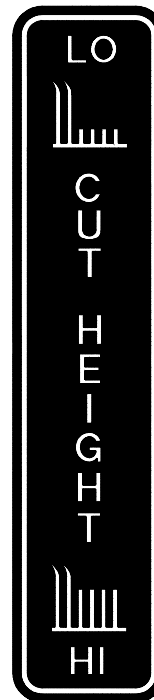

OPERATION INSTRUCTIONS

Safe and successful operation will depend upon the operator having the correct knowledge of all controls used on the mower and making good judgements about the terrain to be mowed.

NEVER allow anyone to operate the mower without complete knowledge of all controls and their functions.

During initial operation, "learning to drive", set throttle at slow speed.

Sound judgement by the operator will prevent accidents.

TOWING

Towing a trailer or other attachment that is too heavy could damage the drive or cause the mower to become unstable. Limit loads to 250 pounds or less on this mower.

BEFORE OPERATING MOWER:

1. Read engine manufacturer's operating and maintenance instructions.
2. Discuss proper maintenance with your dealer.
3. Read and observe all safety instructions on your mower and in the manual.
4. Check engine oil.
5. Be sure gas cap is in place.
6. Be sure parking brake is on.
7. Be sure mower blade drive is off.
8. Know how to stop engine. (Turn key to off position)

OPERATION INSTRUCTIONS



TESTING OF SAFETY INTERLOCK SYSTEMS:

PARKING BRAKE SWITCH TEST:

- a) Place Parking Brake in OFF position
- b) Turn ignition switch to START

Engine should not turn over or attempt to start.

BLADE DRIVE SWITCH TEST:

- a) Place Parking Brake in ON position
- b) Engage blade drive switch
- c) Turn ignition switch to START

Engine should not turn over or attempt to start.

SEAT SWITCH TEST:

- a) In a SAFE AREA away from bystanders, start the engine
- b) Engage blade drive switch
- c) Raise slightly off seat

Engine should stop!



If Any Safety Check FAILS: Do Not Operate The Mower until the system has been checked and repaired by an Authorized Dixon ZTR Dealer

OPERATION INSTRUCTIONS

STARTING INSTRUCTIONS:

1. Parking brake must be on, and blade drive disengaged.
2. Move throttle control to "Choke" position if engine is cold, full throttle if warm.
3. Insert ignition key and turn to "Start" position. When engine starts, release ignition key. Key will return to "Run" position.
4. Move throttle from "Choke" to desired speed position.
5. Release parking brake.
6. Operate the mower per the "Control" instructions on page 14.

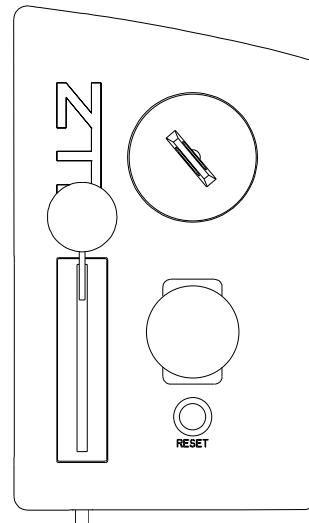

NOTE: While mowing, "blade(s) engaged", throttle control must be set to the **MAXIMUM** or wide open setting to insure adequate cooling of the engine and to maintain mower deck blade speed.

OPERATION INSTRUCTIONS

MOWING WITH A MULCHING ATTACHMENT:

Mulching or recycling the grass clippings requires a totally different mowing approach than would be normal when side discharging or bagging the grass. There may be instances or conditions where it is not possible to hide all of the recycled or mulched clippings.

In order to achieve the best results, please read and follow the mulching tips listed below:

1. Set the engine speed control to the wide open or full setting.
2. Place the mower deck cut height selector in either the top or second notch. Never cut more than 3/4" to 1" off the grass at any one time. Attempting to cut more grass will result in the deck plugging and cause the engine to stall.
3. It may be necessary to cut the lawn twice to achieve acceptable mulching performance especially on first cuttings or if the lawn is heavily fertilized.
4. *Do Not Attempt To Cut Grass When It Is Wet.* Mulching performance will be very poor under wet grass conditions.
5. *Maintain Sharp Blades Throughout The Cutting Season.* This is very important. Optimal mulching performance cannot be obtained with dull or nicked up blades.
6. *Keep The Underside Of The Mower Deck Clean.* Remove all grass and dirt buildup from the underside of the pan, the baffles and deflectors after each use.
7. Alternate mower direction. This will evenly disperse the mulched grass clippings over the lawn for even fertilization.

If the mulching quality of the mower does not seem to be satisfactory, try one or more of the following tips:

1. Raise the height-of-cut setting on your mower.
2. It may be necessary to cut your grass more frequently.
3. Operate the mower at a slower ground speed.
4. Overlap cutting swaths instead of cutting a full swath with each pass.
5. Mow across the marginal areas a second time.
6. **CUT HIGH - MOW OFTEN!**

OPERATION INSTRUCTIONS

MOWING WITH A GRASS CATCHER ATTACHMENT:

In order to achieve optimum performance when mowing with a grass catching attachment, please read and follow the tips listed below.

1. Some applications may require installation of an optional weight box on the front of the mower to offset cut grass weight.
2. Set engine speed control to the wide open or full setting.
3. *Do Not Attempt To Cut Grass When It Is Wet.* Wet grass will clog both the underside of the deck and the attachment chutes. Empty bags often to prevent plugging.
4. If the grass is tall, place the mower deck cut height selector in the top or second notch. "Initially" overlap cutting swaths instead of a full swath with each pass.
5. *Keep The Underside Of The Mower Deck Clean.* Frequent removal of dried grass and dirt will greatly assist in bagging of the clippings.
6. *Maintain Sharp Blades Throughout The Cutting Season.* Some grass catching attachments require "high-lift" blades.
7. Operate the mower at a slower ground speed than when mowing without a grass catching attachment.

CAUTION

- Watch for low hanging branches or other obstacles which might hit the catcher top while turning or backing the mower.
 - Use care when backing to avoid pushing the grass bags into the frame or "hot" exhaust muffler of the engine.
 - Disengage blade and stop engine prior to clearing grass from either the discharge chute or grass catcher components.
 - Keep all attachment bolts tight.
 - Do Not operate the mower with the grass catching attachment partially removed.
 - Important:
 - Do not leave clippings in the bags while the mower is stored.
 - Damp grass clippings are a fire hazard if left in the bags.
-

OPERATION INSTRUCTIONS

SIDE DISCHARGE OF THE CLIPPINGS:

In order to achieve optimum performance when side discharging the grass clippings, please read and follow the tips listed below.

Additional information can be found in the troubleshooting guide.

 **CAUTION** Be sure that deflector is properly installed on the discharge chute.

1. Set engine speed control to the wide open or full setting.
2. *Do Not Attempt To Cut Grass When It Is Wet.* Wet grass will clog the underside of the deck and discharge area.
3. If the grass is tall, place the mower deck cut height lever in the top or second notch. Initially overlap cutting swaths instead of a full swath with each pass. Some applications may require a second cutting.
4. *Keep The Underside Of The Mower Deck Clean.* Frequent removal of dried grass and dirt will allow the clippings to discharge correctly.
5. *Maintain Sharp Blades Throughout The Cutting Season.*

GRASS HEIGHT SUGGESTIONS:

Correct mowing height can reduce weeds and disease by 50 to 80%

The following grass cut heights are based on adequate moisture conditions and normal thatch buildup in a healthy lawn. Some locations and applications may require slightly different cut heights. If in doubt, consult your local lawn professional for assistance.

Grass Types:	Best Cut Heights
Zoysia	2" - 2 1/2"
Blue Grass	1 1/2" - 3"
Fescue Blends	1 1/2" - 3"
St. Augustine (Mid South)	1 1/2" - 2"
St. Augustine (Deep South)	3" - 4"
Tifton Bermuda	1 1/2"
Centipede	1 1/2" - 2"
Common Bermuda	1 1/2" - 2"
Bahia/Argentina/Pensacola	2"

CARE AND MAINTENANCE

This portion of the owners manual deals with normal service items which can be performed by the owner. Please remember that if you are in doubt as to the correct service procedures to be followed, these and other service situations can be handled by a Dixon ZTR dealer who is familiar with the service of your mower.

MAINTENANCE SCHEDULE:

To insure a long and trouble free service life of all components, a regular and thorough maintenance schedule should be followed. The following items should be checked after the first (10) hours of operation and on a weekly basis, or each (40) hours of use:

1. Drive Chain
2. Drive system, belts and controls.
3. Mower deck belts.
4. Tire pressures.
5. Tightness of all nuts and bolts.
6. Battery fluid level.
7. Engine Oil.



CAUTION

Before performing any maintenance,
shut off engine, allow to cool.

ENGINE: For engine operating and maintenance information, refer to the engine operating and maintenance instructions furnished by the engine manufacturer, supplied with each mower.

BATTERY: Check the fluid in the battery at frequent intervals.

Keep fluid level above the plates in each cell, using distilled water.

OFF-SEASON BATTERY STORAGE:

Identify each cable so cables can be reconnected to correct terminals.

Disconnect cables from terminals

ALWAYS disconnect ground cable first and reconnect last

Charge battery.

DO NOT remove battery from mower.

Clean top of battery and terminals with baking soda and water.

CARE AND MAINTENANCE

CUTTER BLADE MAINTENANCE:

NOTE: Observe proper blade position prior to removal.

1. Safely raise front of mower.
2. Hold or block blade from turning.
3. Loosen blade nut and remove blade.
4. When replacing blade, tighten blade nut securely. Refer to diagram.

⚠ CAUTION Wear heavy, thick gloves when holding onto cutter blade.
Avoid touching the sharp edge of the blade.

NOTE: BE SURE BLADE IS CENTERED ON PILOT BEFORE TIGHTENING NUT TO 60 FT. LBS. TORQUE.

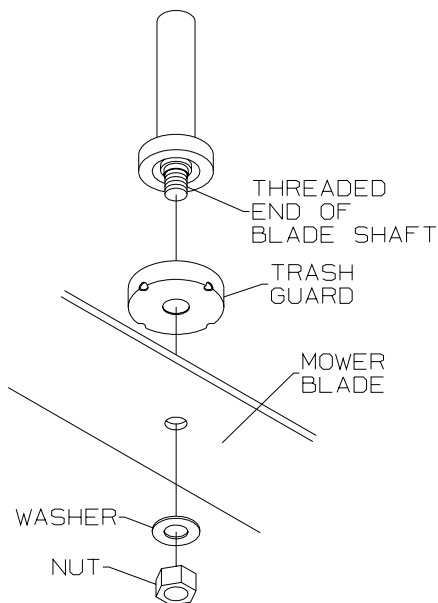

CARE AND MAINTENANCE

BELT TENSION

TRANSAXLE DRIVE BELT: P/N 7650

No adjustment required.

ENGINE TO MOWER DECK BELT: P/N 7725

No adjustment required.

Correct belt tension is maintained through a fixed engine location and a spring loaded idler system.

A pulsing movement of the belt idler will be observed both during engagement of the electric blade clutch and actual operation of the mower deck.

NOTE: Engagement of the electric blade clutch switch may produce a sharp high pitched chirp or squeal as the belt tension loading is absorbed by the idler system. This is normal and not a sign of failure.

MOWER DECK SERPENTINE BELT: P/N 6109

Refer to illustration for adjustment procedure.

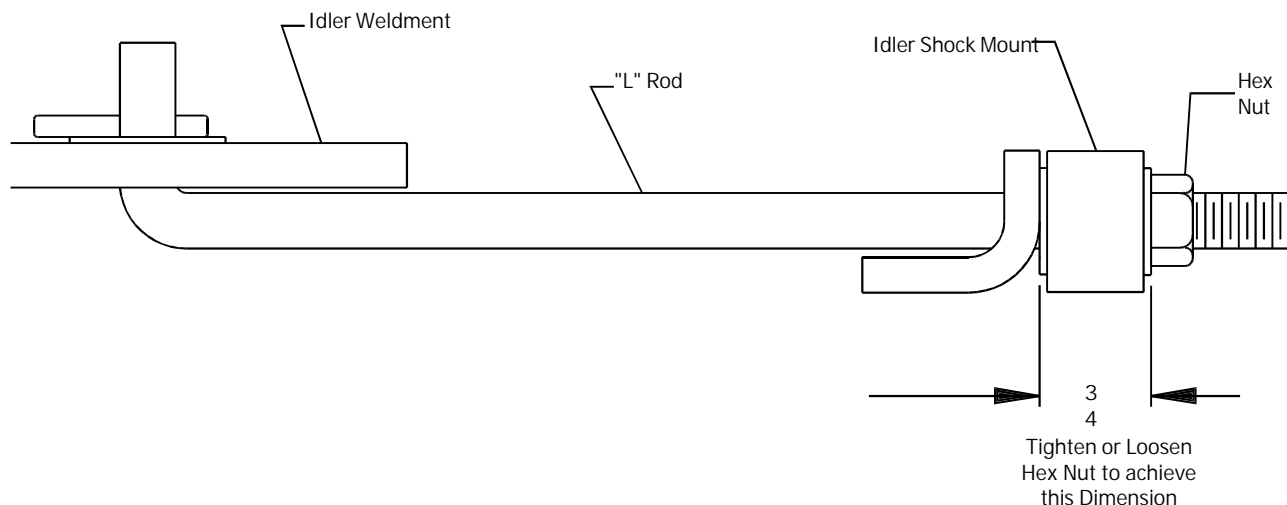

CARE AND MAINTENANCE

MOWER DECK LEVELING PROCEDURE:

1. Place mower on a smooth, level surface and check tire pressures to insure correct stance. Tires should be inflated as follows:

Front: 16 - 21 lbs

Rear: 8 - 14 lbs

2. Turn each outer blade tip to align with the deck in a side to side manner.
3. Measure from the floor surface up to the bottom of the blade tip on the discharge side of the mower. Retain this measurement. Move to the opposite side and check to see if that measurement is the same. *If adjustment is required, turn nut on one or both of the rear L-rods until both measurements are equal.*
4. Turn each outer blade tip to align with the deck in a front to rear manner.
5. Measure from the floor surface up to the bottom of the blade tips at *both the front and rear of the blades*. Rear of blade tips should be 1/8" to 3/8" higher than the front of blade tips. If adjustment is necessary, turn nut on front L-rod.

NOTE: This will place the mower deck in a base measurement position. Additional adjustment may be required to achieve desired cut for the type of grass or conditions involved.

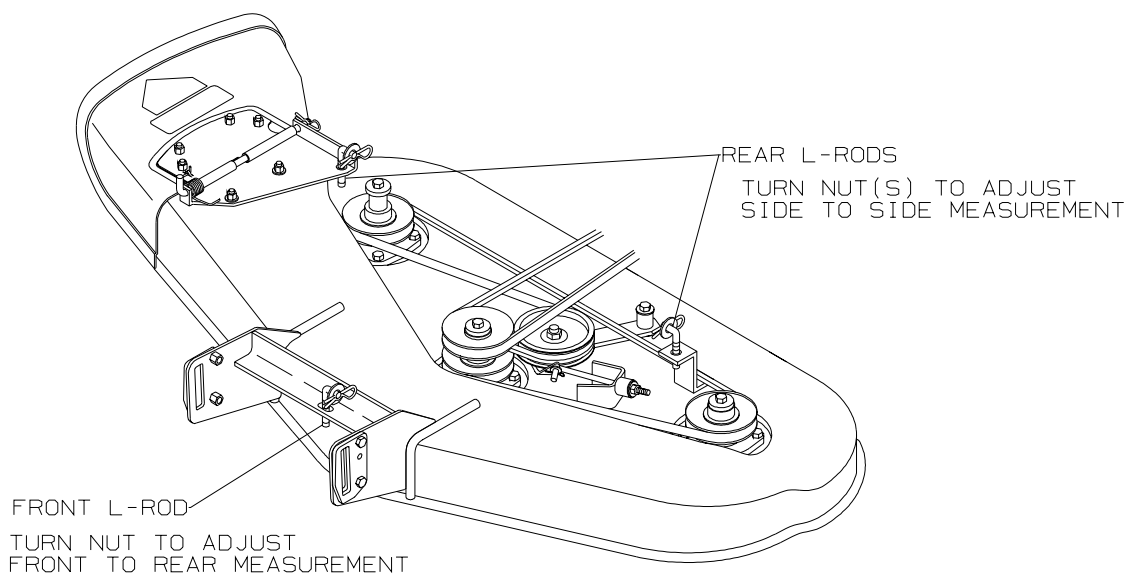

CARE AND MAINTENANCE

DECK REMOVAL:

1. Place cut height lever in lowest cut position.
2. Pull belt idler back to allow belt to be removed from idler pulley and electric clutch pulley.
3. Remove hair pin cotter and washer from one end of deck support cross shaft. Note location of remaining shim washers used between chassis and mower deck plates. Slide shaft from chassis and mower deck.
4. Remove hair pin cotter and washer from each deck L-rod. Remove L-rods from lift arms. At this point, deck will drop down.
5. Carefully raise and support front of chassis. Slide mower deck to either side for removal. (Reverse procedure to reinstall deck assembly).

NOTE: When deck is reinstalled on frame, check that belt is correctly routed in the groves of all pulleys and that belt idler is applying tension to the back side of the belt.

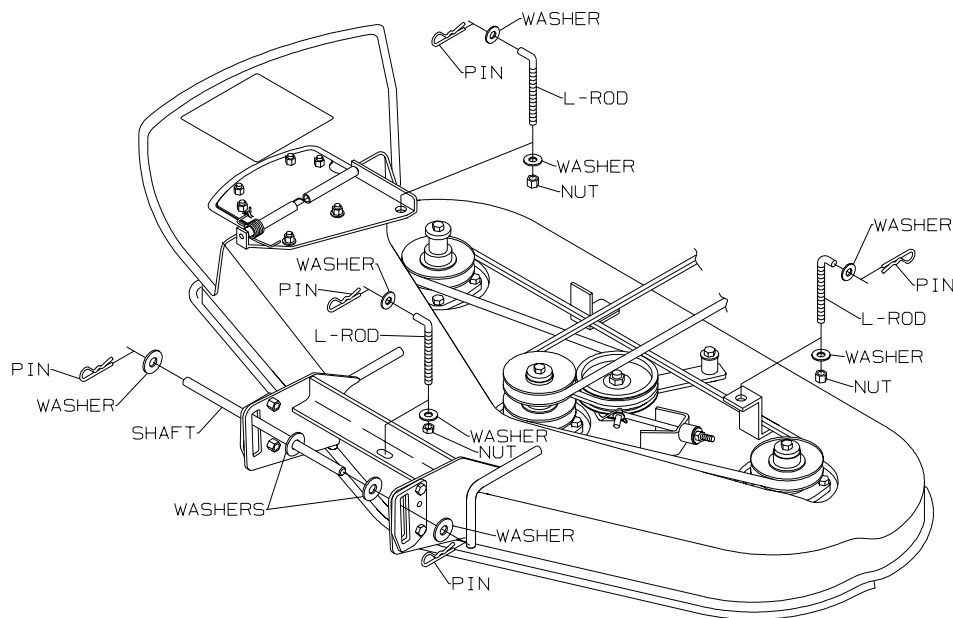

CARE AND MAINTENANCE

⚠ CAUTION HOT oil may cause burns. Allow engine to cool before draining oil.

CHANGING THE ENGINE OIL:

1. The "Dapco" oil drain valve is located on the left side of the engine crankcase.
2. Place a suitable container under the drain valve. The fitting of a short piece of hose will help direct the oil.
3. To drain turn hex head valve stem counter clockwise with 10mm wrench or socket. Open to full open (approximately 7 turns).
4. After engine is drained tighten hex stem..

NOTE: Refer to engine manufacturers recommendations for frequency of oil changes.

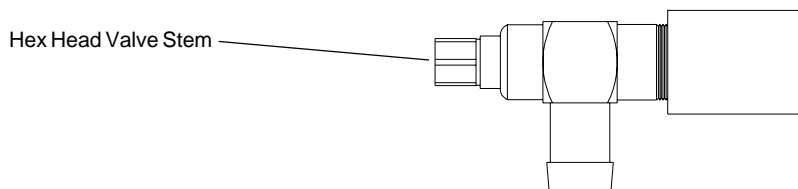

OIL FILL:

1. Drain oil.
2. Clean any spilled oil from engine and chassis.
3. Refill engine with type, and quantity of oil recommended by the engine manufacturer in engine literature.

OIL FILTERS:

- Replace filter each time the oil is changed.
- These filters can be obtained from your authorized Briggs & Stratton engine dealer (P/N 492 932).
- *The use of any other oil filter may cause damage to the engine.*

***PLEASE DISPOSE OF USED OILS AT PROPER COLLECTION CENTERS.
PROTECT YOUR ENVIRONMENT***

CARE AND MAINTENANCE

LUBRICATION:

CHASSIS: Number of grease zerks used: (7)

LOCATIONS: (1) each front wheel caster and each front wheel hub.
(1) each mower deck

SERVICE INTERVALS: Every 50 hours of operation.

RECOMMENDED GREASE: Name brand wheel bearing or multi-purpose grease.

Once per season or every 50 hours of operation (3 pumps each).

Lubrication of the mower deck hubs will help dispel moisture within the hub casting. Bearings are of a sealed variety.

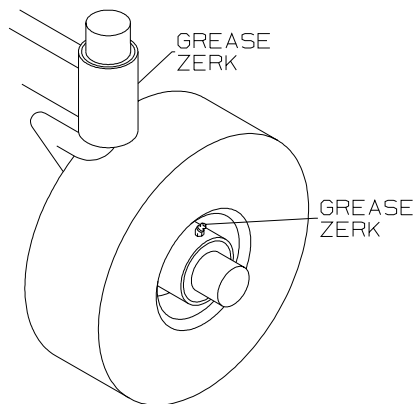

***PLEASE DISPOSE OF USED OILS AT PROPER COLLECTION CENTERS.
PROTECT YOUR ENVIRONMENT***

CARE AND MAINTENANCE

DRIVE SYSTEM ADJUSTMENTS:

Due to both the complex nature of the transmission and the number of special tools required for service, adjustments should be entrusted to your dealer.

There are a number of simple owner service items which greatly influence the performance of the drive system.

1. Front and rear tires must be inflated to proper specifications.
2. Rear drive chain tension.
3. Tightness of all controls and linkages pertaining to the drive levers.
4. Lubrication of both primary and final drive chains.

(The use of a high quality chain lubricant is highly recommended.)

REAR CHAIN ADJUSTMENT:

Proper tension for the rear drive chains is accomplished through the use of an "automatic" adjuster located at mid-point of each rear chain.

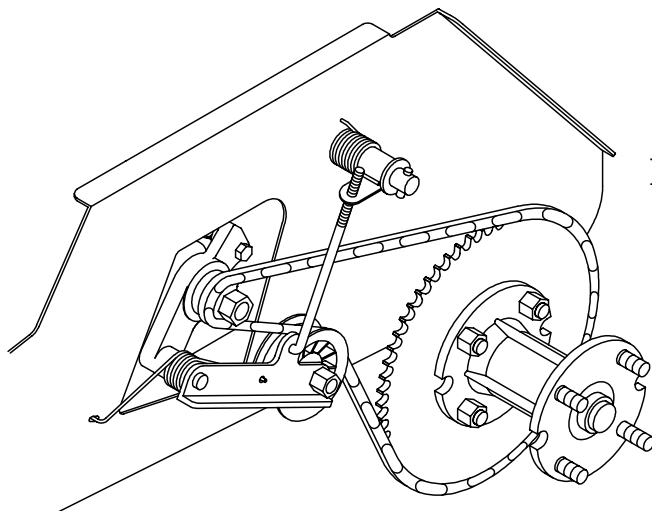

Maintenance:

Periodically remove any build up of grass, mud or other debris from both the spring loaded roller and the upper guide rod.

The use of a penetrating lubricant on the springs and rod is recommended as a rust preventative.

CARE AND MAINTENANCE

WHEELS AND TIRES: Correct tire pressure is important for correct operation of mower.

Front Tires	11 X 4.00 X 5	16-21 lbs. PSI
Rear Tires	18 X 9.50 X 8	8-14 lbs. PSI

NOTE: Check lug nuts periodically for tightness.

ELECTRICAL SYSTEMS: Keep all connections clean and tight.

CLEANING THE MOWER: Wash mower periodically. Clean above and below deck.

NOTE: Allow mower to cool before washing. If bearings are hot, they will draw moisture inside as they dry and cause corrosion.

MOWER DECK PLATES: Check periodically. Replace bolted-on wear plates before shaft wears into mower deck plates. See illustration.

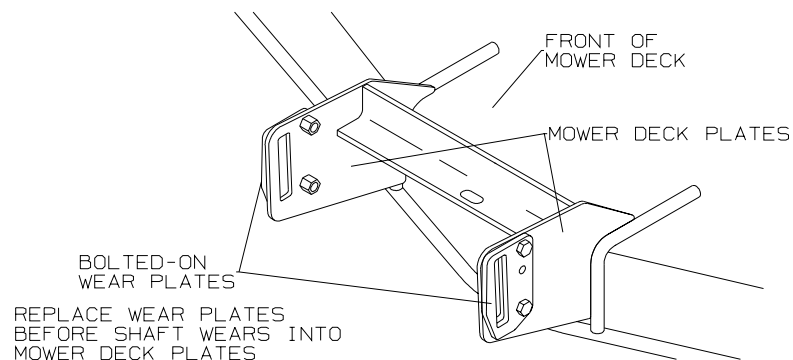

SERIAL NUMBERS: The serial number is located on frame at rear of engine, it will begin with DM.

WARRANTY: Refer to Warranty Registration Form (P/N 8288).

PARTS/SERVICE: See your Dixon dealer for replacement parts, warranty or service.

PLEASE HELP PROTECT THE ENVIRONMENT BY AVOIDING ALL CHEMICALS WHICH MAY DAMAGE OR CAUSE HARM TO PLANTS AND ANIMALS IN YOUR AREA.

STANDARD SERVICE PARTS LIST

BLADES:	Lo-Lift:	P/N 6236
	Standard Hi-Lift:	P/N 8688
BELTS:	Engine To Mower Deck:	P/N 7725
	Serpentine Belt:	P/N 6109
	Engine To Transmission:	P/N 2497

BRIGGS & STRATTON FILTER PART NUMBERS:

Please refer to Briggs & Stratton Engine Operators Manual for correct service intervals for engine oil changes and air filter maintenance.

Protect your engine investment, use only original equipment filters.

Air Filter & Precleaner Kit:	P/N 79002
Engine Oil Filter:	P/N 79006

TROUBLESHOOTING

MOWER CUT QUALITY:

There are many variables that can effect the cut quality of any riding mower. Type and conditions of grass, cut height setting, engine RPM and ground speed are some of the variables that interact creating differences in cut quality. Examination of one or more of the above will generally produce a quality cut.

The Troubleshooting Chart suggests practices and adjustments that may be helpful in improving cut quality. Your Dixon ZTR dealer is also available to provide assistance to you.

<u>SITUATION</u>	<u>CAUSES</u>	<u>REMEDY</u>
Poor cut quality	Ground speed too fast	Reduce mowing speed
Poor cut quality mower deck belt	Incorrect engine to	Install correct belt P/N 7725
Poor cut quality	Engine RPM too low	Increase engine RPM to maximum
Poor cut quality	Dull or bent blade	Sharpen or replace as required
Poor cut quality	Un-level mower deck	Refer to page 25
Poor cut quality	Grass buildup under mower deck	Clean out underside of mower deck
Poor cut quality	Improper blades	Replace with original equipment blade designed for the 4000 Series Models Refer to page 31
Poor cut quality	Uneven tire pressures	Check and adjust as required per operators manual

TROUBLESHOOTING

DRIVE SYSTEM:

<u>SITUATION</u>	<u>CAUSES</u>	<u>REMEDY</u>
Mower pulls to one side or the other	Drive adjustment	Consult your dealer for repair
Poor driving performance	Operation of mower	Review operators section of owners manual

TROUBLESHOOTING

ELECTRICAL SYSTEM:

<u>SITUATION</u>	<u>CAUSES</u>	<u>REMEDY</u>
Starter will not turn engine over	Circuit breaker disengaged	Push button to reset Consult your dealer for repair
Starter will not turn engine over	Dead Battery	Charge battery
Battery discharge	Poor connections on battery Battery water low Wrong battery installed in mower	Tighten or replace as required
Battery discharge	Engine electrical system not functioning correctly	Have electrical system checked by your dealer
Battery discharge	Engine not being operated at full throttle	Increase engine RPM Contact your dealer for information

NOTE: Electrical system failures are generally simple in nature, always check the obvious first and then move onto the more complicated parts used.

Poor battery service, loose connections, corrosion, frayed or broken wiring, are more likely than component failure.

OWNER INFORMATION



DIXON INDUSTRIES, INC.
A BLOUNT International Inc. Co.
PO BOX 1569
COFFEYVILLE KS 67337 0945
316 251 2000
FAX 316 251 4117



DATE PURCHASED _____

MOWER MODEL NUMBER _____

MOWER SERIAL NUMBER **DM-** _____

PURCHASED FROM _____

Name

Address

DATE OIL CHANGED:

DATE ENGINE TUNED:



ZTR[®] Mowers

⚠ WARNING: *The engine exhaust from this product contains chemicals known to the State of California to cause cancer, birth defects or other reproductive harm.*

Dixon[®] and ZTR[®] are registered trademarks of Dixon Industries, Inc.

DIXON INDUSTRIES, INC.
A BLOUNT International Inc. Co.
PO BOX 1569
COFFEYVILLE KS 67337 0945
316 251 2000

*4000 Series
4423
Part No. 13087-0400*